

# Homestead Implements Pinnacle Series Core Aerator

## Technical Specification

Model Numbers	HI-P-CA-48	HI-P-CA-60	HI-P-CA-72
3-Point Hitch Type	Cat. I (Quick-Hitch Compatible)		Cat. I & Cat. II (Quick-Hitch Compatible)
Recommended Horsepower	20 - 60 HP		
Working Width	41.00"	56.00"	71.00"
Overall Width	49.25"	64.25"	79.00"
Overall Length	29.85"		
Overall Height	38.41"		
Total Weight	255 Lbs.	300 Lbs.	355 Lbs.
Numbers of Spoons	48	64	80
Spoon Spacing	7.75"		
Plug Size	1/2"		

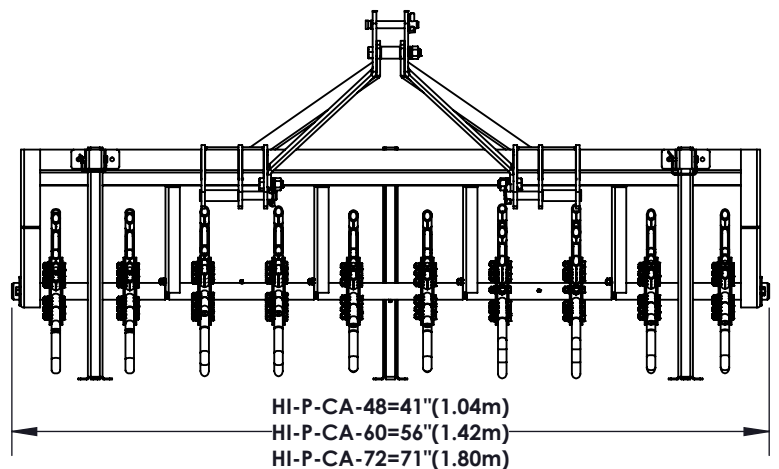
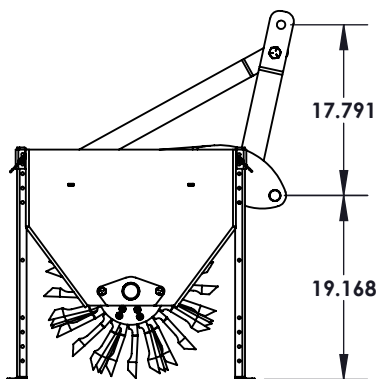

CUSTOMER APPROVAL :

DATE :



THIS DRAWING, WHICH CONTAINS PROPRIETARY INFORMATION, IS THE PROPERTY OF JAMESTOWN ADVANCED PRODUCTS CORPORATION. IT SHALL NOT BE REPRODUCED IN ANY MANNER NOR DISCLOSED TO THIRD PARTIES WITHOUT WRITTEN PERMISSION OF JAMESTOWN ADVANCED PRODUCTS CORPORATION.

DATE : **5/16/22**

PRODUCT PART NUMBER : **HI-P-CA**

REV. NO.

PRODUCT DESCRIPTION :

**PINNACLE CORE AERATOR**

2855 GIRTS ROAD  
JAMESTOWN, NY 14701